

## Double Slit Interference: Measuring the Wavelength of Light Spring 2009

### Introduction

The purpose of this experiment is to measure the wavelength of the red light from a Helium-Neon laser *and* to include an estimation of the uncertainty in this result. **Note:** *There will be several lasers turned on throughout the lab; exercise caution at all times!*

### Theory

The following diagram defines the variables. We will assume that the screen is far enough away from the slits so that the small angle approximations are valid.

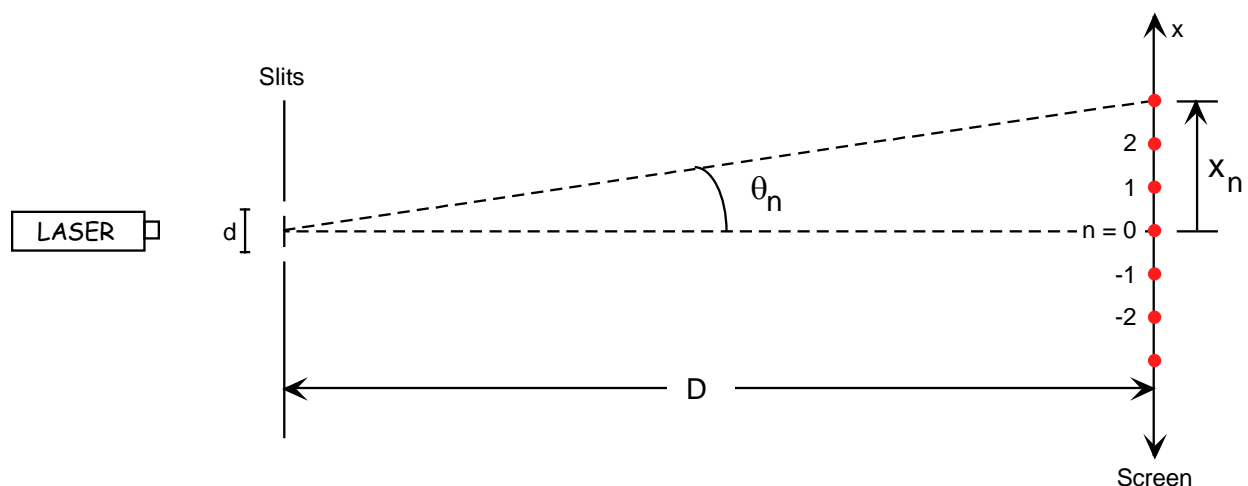

The condition for constructive interference is

$$n\lambda = d \sin \theta_n \approx d \tan \theta_n = d \frac{x_n}{D}$$

Solving for the positions of the bright spots we get, after some rearrangement,

$$x_n = \lambda \frac{D}{d} n$$

If we plot  $x_n$  vs.  $n$ , we should get a straight line passing through the origin with a slope  $m = \lambda \frac{D}{d}$ . Since we can easily measure  $D$  and with a bit of work find  $d$ , it is straightforward to get the wavelength by  $\lambda = m \frac{d}{D}$ .

## Experiment

1. Shine a laser directly on the center pair of double-slits on the Cornell slide (shown at right) so that a good double slit interference pattern is illuminated on a piece of paper taped to the wall. Measure  $D$ , the distance from the Cornell slide to the wall (mark the position of the slide on the bench with tape so that the distance can be checked later).
2. With a pencil, mark the centers of the bright spots along the entire length of the paper; you may find it useful to use a ruler to mark the spot centers along a straight line. Remove the paper from the wall. Label the center spot  $n = 0$ , and the adjacent ones  $\pm 1$ ,  $\pm 2$ , etc. Remember that single slit diffraction puts a *min* on top of a double-slit interference *max*, so if a spot seems to be “missing”, make sure you *skip* a number! After numbering the spots, measure their positions, choosing  $x = 0$  to be at the  $n = 0$  spot.
3. Enter your data in KaleidaGraph and find the slope of the  $x$  vs.  $n$  line *and its uncertainty*.
4. The slit separation can be determined using the following procedure: place the Cornell slide in the slide projector in the orientation shown at right, and focus the image on the wall. Measure  $d_{\text{wall}}$ , the projected distance between the *centers* of the pair of slits used, as shown at right; also measure  $L$  as shown above. You can then measure this distance directly on the slide and figure out the scale. When you have worked all this out, *report  $d$  and your estimate of its uncertainty (using the expansion method as explained below)*.

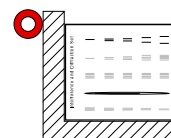
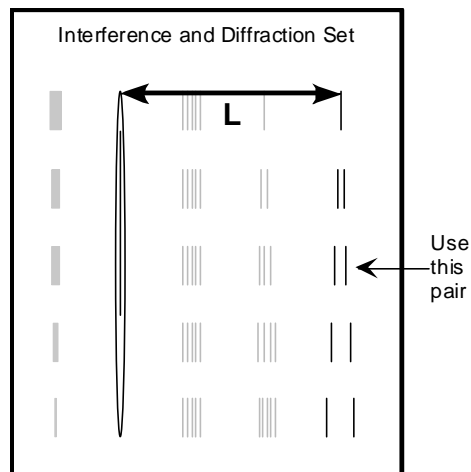

## Analysis

You should need no help in calculating the wavelength. But how do we calculate the uncertainty in wavelength given the uncertainties in each of the quantities that go into that calculation? Whenever the equation involves only multiplication and division, the answer is given by a simple rule. In this case

$\lambda = m \frac{d}{D}$ , and the rule says:

$$\left(\frac{\Delta\lambda}{\lambda}\right)^2 = \left(\frac{\Delta d}{d}\right)^2 + \left(\frac{\Delta D}{D}\right)^2 + \left(\frac{\Delta m}{m}\right)^2$$

In this case,  $\frac{\Delta D}{D}$  should be tiny in comparison to the other terms, so you can ignore it. This tells you that the

measurement of  $D$  is the *least* critical in the experiment.  $\Delta m$  is the uncertainty in the slope, which is *twice* the standard error calculated by KaleidaGraph.  $\Delta d$  is the uncertainty in the slit separation, and is calculated

in the same manner; since  $d = L \frac{d_{\text{wall}}}{L_{\text{wall}}}$  we can make a similar expansion:

$$\left(\frac{\Delta d}{d}\right)^2 = \left(\frac{\Delta L}{L}\right)^2 + \left(\frac{\Delta d_{\text{wall}}}{d_{\text{wall}}}\right)^2 + \left(\frac{\Delta L_{\text{wall}}}{L_{\text{wall}}}\right)^2$$

5. Calculate  $\Delta\lambda$  and report your final result in the form  $\lambda \pm \Delta\lambda$  (use units of *nanometers*:  $1 \text{ nm} = 1 \times 10^{-9} \text{ m}$ ).
6. Compare your calculated wavelength to the actual value and see if your result is consistent.

## Discussion

- Restate your calculated value and uncertainty of  $\lambda$ , and discuss the errors involved in its calculation.
- Which measurement is the *most* critical in this experiment? Why?