

Lab 3

RC Circuits

Part 1:

- Is this circuit an integrator or a differentiator?
- Drive the circuit with a 100 kHz square wave. (ie the voltage input should be a square wave.) Carefully draw the output waveform and the input waveform together. Make sure to indicate the voltage scale for each signal and the time scale.

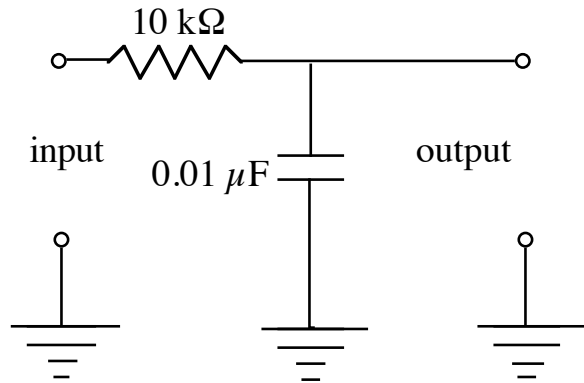

- What do you expect the output waveform to look like? Justify your answer as explicitly as you can. In other words figure out a way to turn the input wave into a mathematical function and do the integral or take the derivative (no numbers are necessary). Make sure you pay attention to negative and positive portions of the wave. If you expect a phase difference explicitly show what it is.
- Is what you see consistent with your expectations?
- Repeat each step you did using a square wave with a triangle wave and then with sinusoidal wave.
- Using the triangle wave find the frequency where this circuit stops behaving as an integrator or differentiator. Does it work for frequencies above or below this frequency. For example, look at the frequency $1/2\pi RC$. Do we expect the circuit to begin working at ten times this frequency or one tenth of this frequency?

Part 2:

Repeat part 1 using the circuit shown on the right.

