

Electrical Resonance—RLC circuits

Purpose: To investigate resonance phenomena that result from forced motion near a system's natural frequency. In this case the system will be a variety of RLC circuits.

Theory: You are already familiar with the concept of resonance. For example, if you pluck a string on an instrument it will vibrate at its resonant frequency. If you hit a rod against a table, it will vibrate at its resonant frequency. The amplitude of the vibration is always largest at the resonance frequency. The quality factor, or Q , is one parameter scientists use to describe resonant systems. The higher the Q , the longer a system will resonate. This means that there is a lower damping of the resonance. Check out sections of your textbook that are related to resonance. In this lab you should become conversant with the concepts of resonance frequencies and quality factor, Q . We are going to investigate a simple driven RLC series circuit.

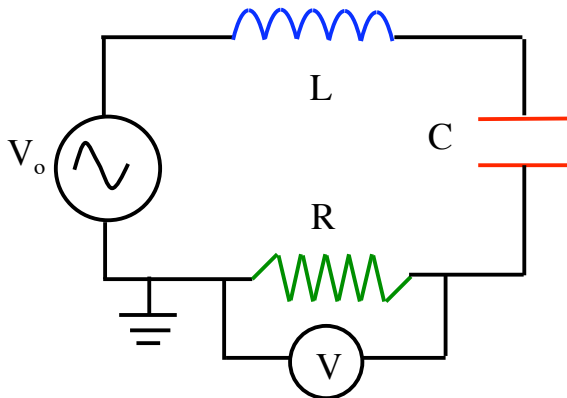

Figure 1 shows a driven RLC circuit where V_o is the applied sinusoidal voltage from the function generator and V is the voltage measured across the resistor using an oscilloscope.

OVERVIEW

You will be testing one RLC circuit. You will determine the resonance frequency, f_o , **and** the quality factor, Q , in several different ways.

- 1) You will use the measured values of the circuit elements to calculate the Q **and** the resonant frequency. Remember to take into account the resistance of the function generator. See Appendix A for details.
- 2) You will use a function generator and an oscilloscope to measure the voltage across the resistor (proportional to the current) as a function of the driving frequency. From this information you can determine the Q and the resonant frequency.
- 3) You will use the transient method to determine Q .

Electrical Resonance—RLC circuits

- 4) You will use a lock-in amplifier technique to determine the resonant frequency and Q.

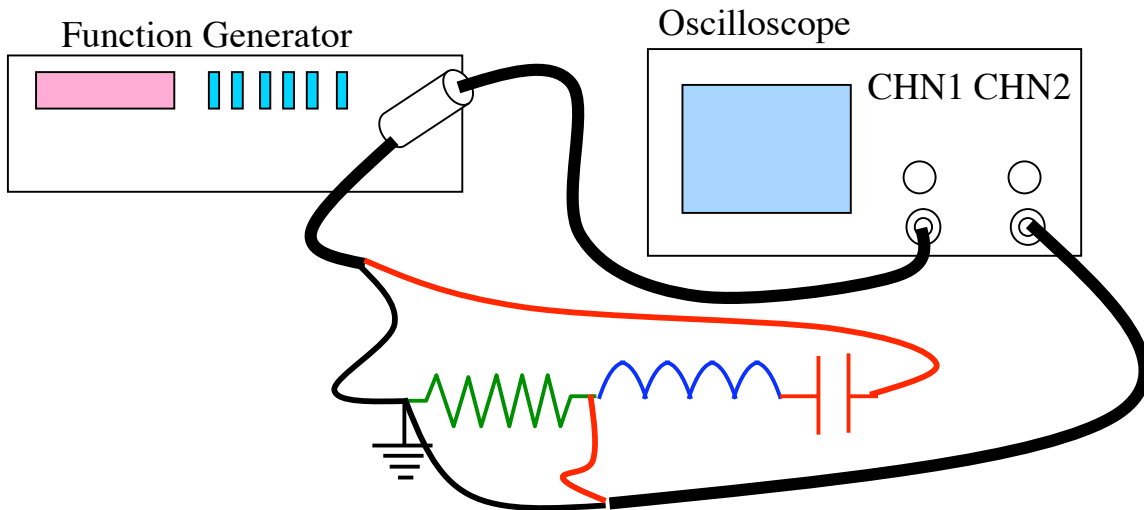

Figure 2 shows the setup for the experiment where the driving voltage amplitude from the function generator is measured on channel 1 and the voltage across the resistor is measured on channel 2.

Procedure:

1) Calculating f_0 and Q from measured component values.

a) You will be given a resistor and a capacitor. Using the multimeters provided, measure their resistance, R , and capacitance, C , respectively. You will also have an inductor; measure its resistance, R_L , and inductance, L . Assume that the internal resistance of the function generator, R_G , is 50Ω .

b) Calculate the resonance frequency of your circuit.

$$\omega = 2\pi f, \omega_0 = \sqrt{\frac{1}{LC}}, \quad f_0 = \frac{1}{2\pi} \omega_0 = \frac{1}{2\pi} \sqrt{\frac{1}{LC}} \quad (2)$$

You should be able to derive this equation from equation (1)

c) Calculate Q from the measured values of the elements in your circuit. Be careful! R is the total resistance of the circuit. $R = R_L + R_G + R_{1or2}$

Electrical Resonance—RLC circuits

$$Q = \frac{\omega_o L}{R} = \frac{1}{\omega_o RC} = (\sqrt{LC}) \frac{1}{RC} = \frac{1}{R} \sqrt{\frac{L}{C}} \quad (3)$$

It would be a good idea to derive these equations in the theory section of your lab report.

2) Measure Voltage as a function of frequency using an Oscilloscope

Set up the circuit shown on page 1 for your circuit. Essentially this is an RLC circuit driven by a sinusoidal voltage produced by the function generator. The oscilloscope is attached across the resistor, and it can be used to measure the voltage across the resistor which is proportional to the current through the resistor. The oscilloscope is also attached to the function generator so that you can measure the driving voltage, V_0 . Be sure to put the ground connectors (black alligator clip) in the same place in your circuit.

a) As with many circuits, you can learn about the RLC circuit's behavior by looking at the current as a function of frequency. The function generator allows you to set the driving voltage, V_0 , and the driving frequency, f . The amplitude of the driving voltage should remain constant while you vary the frequency of the function generator. Make sure you record the amplitude of the driving voltage. Measure the voltage across the resistor as a function of driving frequency making sure that the amplitude of the driving voltage stays constant.

b) In the circuit above, channel 1 measures the applied voltage so you can determine its amplitude and keep it constant. Channel 2 measures a voltage across the resistor. Recall that the oscilloscope plots voltage on the y-axis and time on the x-axis. The magnitude of the voltage can be measured by counting the number of divisions on the scope and multiplying that number by the appropriate voltage/division.

c) Hints to make your life simpler:

Set the amplitude of your function generator to 10 V p-p using channel one of the oscilloscope. Set the frequency to be \sim one order of magnitude lower than the resonance frequency calculated in part 3. Select the sine wave function on the function generator. See oscilloscope hints at the end of these instructions and play around a little bit with the oscilloscope. Increase the frequency and measure the voltage using the scope.

Now you want to see how this circuit behaves around resonance. You will need to set the vertical source to alt or chop in order to observe both channel 1 and 2 (Use

Electrical Resonance—RLC circuits

whichever one looks better. Typically chop works best for low frequencies and alt works best for high frequencies.)

d) Create a data set of frequency and voltage. The voltage on channel one should remain a constant 10 Volts. The voltage on channel two should change with frequency. Make sure you look at frequencies on both sides of the resonance frequency. Take many measurements right around resonance. You will probably need to adjust the V/div scale on channel two several times during the course of the measurements in order to measure the voltages as accurately as possible. Make sure you keep track of this parameter.

e) Plot your data and determine the resonance frequency, f_0 , and Q from the plot. Where f_0 is the frequency at the peak and Q is determined from the width of the peak in the following way.

$$Q = \frac{f_0}{\Delta f} = \frac{\omega_0}{\Delta \omega}. \quad (3)$$

Here Δf is the width of the resonance peak between the points where the voltage is at $\frac{1}{\sqrt{2}} V_{\text{maximum}}$

What is Q a measure of???

What is the resonance frequency according to your data, f_0 , (where the peak is located)? How do the values of Q and f compare to the calculated values from the circuit elements?

3) Measure Voltage as a function of frequency—Lock-in amplifier

a) Next you will measure voltage as a function of frequency for your circuit only this time you will use a **computer driven lock-in amplifier and function generator**. Your instructor will show you how to use the automated lock-in equipment. Don't forget to draw a picture of this experiment in your notebook (and lab report). Do some research to find out what a lock-in amplifier is and how it works. How do you expect the resonance frequency and the Q to differ from your previous circuit. Do your circuits behave as you expect? You should compare them with the other calculated and measured values. Here you should collect two data sets for each of your four circuits (1) the voltage across the resistor (V) as a function of frequency and (2) the voltage across the entire circuit (V_0 , the driving voltage) as a function of frequency.

b) Determining Q and f_0 from the data

Modeling—

From your text, Thornton and Marion's Classical Dynamics, we find the following equation on page 126

Electrical Resonance—RLC circuits

$$I = \frac{V_0}{\sqrt{R_{total}^2 + \left(\frac{1}{\omega C} - \omega L\right)^2}} \sin(\omega t - \delta)$$

The Current will vary sinusoidally just as the driving voltage, V_0 , does. The parameter δ gives us the phase shift between the driving voltage and the current.

Since we are measuring the voltage across the resistor, we can write

$I=V/R$ If we compare either peak to peak measurements (as in the case of your first experiment) or RMS voltages, we can compare the magnitude of the current to the driving voltage giving us the following equation:

$$V = \frac{RV_0}{\sqrt{R_{total}^2 + \left(\frac{1}{\omega C} - \omega L\right)^2}} \quad (4)$$
$$\frac{V}{V_0} = \frac{R}{\sqrt{R_{total}^2 + \left(\frac{1}{\omega C} - \omega L\right)^2}}$$

This equation should look very similar to equation (1). You will use this equation to **fit** your data, which is in the form of V as a function of frequency. The measured driving voltage V_0 comes from data set (2). We expect it to be constant, but is it? You should plot V_0 and V/V_0 as a function of frequency. You may assume that R —the measured value of the resistor—is a fixed parameter. This leaves you with three parameters to vary to fit the data, R_{total} , L and C . Use Kaleidagraph to fit the data. You will need to define a new fit. This will give you new parameters for R , L and C which you can use to get experimental values of the resonance frequency and quality factor of your data.

4) Transients--one other way to determine Q.

When you strike a tuning fork, it vibrates at its natural frequency. In a similar manner, we can “strike” the electrical circuit with a square wave and watch the vibrations die out so that we see a signal that looks something like the picture in figure 3.

Electrical Resonance—RLC circuits

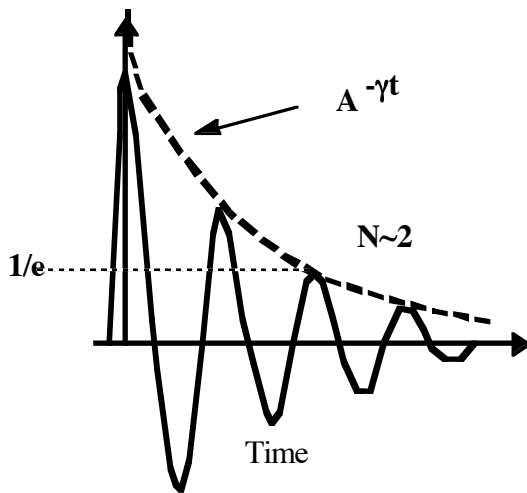

Figure 3 shows the decay of the vibration amplitude of your circuit as a function of time.

To observe this transient behavior, adjust the function generator so that it is supplying a square wave at a couple hundred Hz. Adjust the time and voltage axes on channel two until you see something similar to the drawing shown in figure 3. If you count the number of periods until the $1/e$ point, you will have an estimate of Q . The theory behind this assertion follows:

A damped oscillator behaves according to the following equation:

$$x(t) = A e^{-\gamma t} \cos \omega t$$

at $\frac{1}{e}$ or e^{-1} , $t = NT = \frac{1}{\gamma}$, where T is the period $\left(\frac{2\pi}{\omega}\right)$ and N is the number of them.

Since $Q = \frac{\omega}{2\gamma} = \frac{\omega NT}{2} = N\pi$. Therefore, by counting the number of periods until the $1/e$ points, one can obtain an estimation of Q . In the example above, $N \sim 2.25$, and $Q = 2.25\pi$.

Don't forget to estimate your measurement uncertainty for this part.

Electrical Resonance—RLC circuits

Check List for your report:

- 1) Determine the Q for an RLC circuit in the following three ways:
 - a) Calculate the Q based on the measured values of components R , L , and C .
 - b) Determine Q from your graph of Voltage vs. Frequency from the oscilloscope
 - c) Calculate Q from the fitting parameters of your Lock-in data
 - c) Determine Q from the transients circuit behavior

- 2) Determine the resonant frequency, f_0 , for an RLC circuit in the following three ways:
 - a) Calculate f_0 based on the measurement of R , L , and C .
 - b) Measure f_0 from the peak of the graph of Voltage vs. Frequency from both the oscilloscope data.
 - c) Calculate f_0 from the fitting parameters from the Lock-in data.

- 3) Compare the calculated and measured values of Q . Do they fall within the error range of each other?

- 4) Compare the calculated and measured values of f_0 . Do they fall within the error range of each other?

- 5) How would you expect Q to be affected by changing R ?

- 6) How would you expect the resonance frequency to be affected by changing R ?

- 7) How would you expect Q to be affected by changing C ?

- 8) How would you expect the resonance frequency to be affected by changing C ?

Electrical Resonance—RLC circuits

Appendix A

Model: Ohm's law tells us that $V=IR$. More generally, we can talk about $V=IZ$ where Z is the impedance of a circuit. The following apply

Resistor-- $Z_R = R$,

Capacitor-- $Z_C = 1/i\omega C$

Inductor— $Z_L = i\omega L$

Where $i = \sqrt{-1}$ and $\omega = 2\pi f$ where f is the driving frequency.

When elements in a circuit are in series, their impedances add.

$$\begin{aligned} V &= IZ \\ &= I(Z_R + Z_L + Z_C) \\ &= I\left(R_{total} + i\omega L + \frac{1}{i\omega C}\right) \end{aligned}$$

If we measure the voltage across the resistor, we can determine the current using ohms law $I=V/R$ so that we have the following equation:

$$V_0 = \frac{V}{R_{1or2}} \left(R_{total} + i\omega L + \frac{1}{i\omega C} \right)$$

or

$$V = \frac{V_0 R_{1or2}}{\left(R_{total} + i\omega L + \frac{1}{i\omega C} \right)}$$

Here V_0 is the applied voltage to the circuit (which should remain constant), V is the measured voltage across the resistor, and ω contains the frequency since $\omega=2\pi f$.

We can remove the phase information that is given to us with the imaginary number i , by multiplying by the complex conjugate and taking the square root.

Our final equation is then

$$V = \frac{V_0 R_{1or2}}{\left(R_{total}^2 + \left(\omega L - \frac{1}{\omega C} \right)^2 \right)^{1/2}} \quad (1)$$

Essentially here we have a voltage, V , that should change as we change the angular frequency ω .

Electrical Resonance—RLC circuits

Appendix B

Oscilloscope hints:

The oscilloscope is an instrument that displays voltage on the y axis and time on the x axis. (In x-y mode you can put voltage on both the x and y axes.)

Vertical:

The y-scale allows you to adjust how many voltage divisions you want on the screen. If the scale is set too large, you will not see the signal, rather you would see a horizontal line. If the scale is set too small, you may cut off the top or bottom of the signal. The Gnd function is useful, if you select it, then you know where zero volts is. You should do this every time you change the scale. I recommend using the center line as zero volts until you are more comfortable with the scope. Be sure to put the channel back on DC coupling.

Horizontal:

The horizontal is the time scale for the signal.

You need to adjust the sec/div, here are two methods:

1) twiddle the knob until you see something

2) $\frac{1}{\text{frequency}} = \# \text{ sec}$, the frequency used in this equation is the one on the function

generator. example: if the frequency is 1k Hz, then $\frac{1}{f} = 1 \text{ msec}$, and you might want to choose the 0.5 msec/div scale, or less so that you can see at least an entire wave on the screen.

Trigger:

The trigger tells you which wave you are using to time your display. In this case you want to use the signal from the function generator which is chn 1. Therefore, set the source to chn1, the mode to p-p auto, and coupling to DC.

Appendix C

Lock-in Amplifier

A lock-in amplifier is a phase sensitive detector. It measures the voltage signal, $x=R\cos\theta$, that is of the same frequency and same phase, θ , as the reference signal you give it. In this way, we can measure the voltage as a function of reference frequency as above, only we use the computer to vary the frequency on the function generator and measure the voltage on the lock-in amplifier.