

## THE STEFAN-BOLTZMANN LAW

Electromagnetic radiation absorbed and emitted by any substance is dependent on the temperature of the substance. Josef Stefan showed experimentally in 1879 that for a perfect emitter (a 'black body') the rate at which energy is emitted is related to the object's temperature by

$$R = \frac{P}{A} = \sigma \varepsilon T^4 \quad [1]$$

where  $R$  is the power radiated per unit area,  $A$ ,  $\varepsilon$  is the emissivity which equals 1 for a perfect blackbody,  $A$  is the surface area of the radiator, and  $\sigma$  is the Stefan-Boltzmann constant. This relation was subsequently derived theoretically by Ludwig Boltzmann, who had been a student assistant of Stefan's at the University of Vienna, and later succeeded to Stefan's professorial post there. In 1900 Max Planck showed that the spectral distribution of energy density in a blackbody could be described with what we call the Planck radiation formula:

$$\bar{u}(f)df = \frac{8\pi h}{c^3} \frac{f^3 df}{(e^{hf/kT} - 1)} \quad [2]$$

Here  $u$  has units of energy per volume per frequency,  $f$ . This expression required the use of the quantum hypothesis and marked the first appearance of the quantum of energy,  $hf$ . If we integrate over the range of frequencies from 0 to  $\infty$  we get an expression for the total energy per volume,  $U$ , which is related to  $R$  by a constant  $R=cU/4$ .

### LIBRARY RESEARCH:

Find out more about the following: blackbodies, Stefan-Boltzmann's (T<sup>4</sup>) law, Wien's law.

### THEORY:

Show by integration that the total energy density given by the Planck spectral distribution function is consistent with the Stefan-Boltzmann law, and calculate a value for  $\sigma$ . In other words, integrate equation [2] and multiply by  $c/4$  to find an expression for  $\sigma$ . (Hint: use the dimensionless quantity  $x=hf/kT$  to simplify the integral. Look up the value of the resulting definite integral in  $x$  using a table of integrals. Do not try to evaluate this integral analytically.)

### EXPERIMENT:

You will use a radiation sensor to measure the intensity of thermal radiation. The sensing element, a miniature thermopile, produces a voltage proportional to the

## THE STEFAN-BOLTZMANN LAW

intensity of the radiation. (Look on the sensor to find out the conversion between its reading and power radiation.) **When using the sensor, be careful not to change its position.** You will need to use an insulating material to block the sensor from the radiation so it doesn't heat up. Make measurements quickly so that the sensor does not heat up when exposed to the source.

You will be measuring the radiation emitted by two sources. The 'high temperature' source is a tungsten-filament lamp. The temperature of the filament can be calibrated to the resistance of the filament using an optical pyrometer and that calibration for Tungsten is shown below. The 'low temperature' source is a thermal radiation cube, a Leslie cube. This is a cube of nearly uniform external temperature, heated from inside by a light bulb. Three of the sides of the cube are black, white, and shiny metallic, the fourth is dull metallic gray.

### A. STEFAN-BOLTZMANN LAW AT HIGH TEMPERATURES.

Measure the room-temperature resistance of the bulb to three digits using a four wire probe ohmmeter. We will use this quantity, called  $R_{300K}$  later in our calculations. Next set up the circuit shown below. In order to determine the resistance of the filament and the power dissipated at various temperatures, you will record  $V$  and  $I$  at different voltage levels.

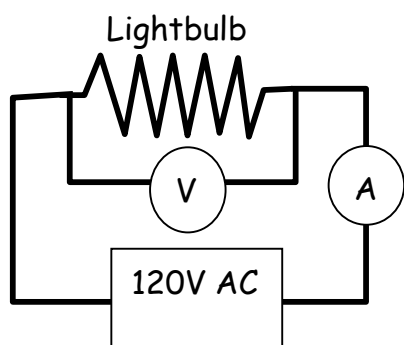

Now set up the radiation sensor so that the aperture is **at least 6cm** from the filament of the lightbulb, and set a piece of insulation between the sensor and the bulb. Expose the sensor by pushing down on the metal shield and hold it open with the retaining ring. Remove the insulating shield only briefly to make readings. Starting at half the voltage of where the filament first begins to glow, record  $V$ ,  $I$ , and the sensor's output in mV, every 5V up to about 110V.

Record  $V$ ,  $I$ , and the thermopile voltage at each voltage level.

**Analysis:** You will need to determine the temperature of the light bulb. First make a calibration curve using the resistance and temperature data in the table below. Find an equation that will allow you to convert  $R/R_{300K}$  to Temperature. Next Calculate  $R$  ( $R=V/I$ ) and  $R/R_{300K}$  for your data, and convert  $R/R_{300K}$  to temperature using the equation you determined from the calibration curve. Find the light bulb power by calculating  $P=VI$  at each voltage. Convert the thermopile's voltage reading into a power measurement using the conversion printed on the

## THE STEFAN-BOLTZMANN LAW

thermopile. Plot the two powers you have measured vs  $T^4$ . Do your data support the Stefan-Boltzmann law?

### TUNGSTEN RESISTANCE VS TEMPERATURE

R(Ohm)	R/R300	T(K)	R(Ohm)	R/R300	T(K)	R(Ohm)	R/R300	T(K)
	1.00	300		7.14	1500		14.34	2700
	1.43	400		7.71	1600		14.99	2800
	1.87	500		8.28	1700		15.63	2900
	2.34	600		8.86	1800		16.29	3000
	2.85	700		9.4	1900		16.95	3100
	3.36	800		10.03	2000		17.62	3200
	3.88	900		10.63	2100		18.28	3300
	4.41	1000		11.24	2200		18.97	3400
	4.95	1100		11.84	2300		19.66	3500
	5.48	1200		12.46	2400		20.35	3600
	6.03	1300		13.08	2500			
	6.58	1400		13.72	2600			

### B. STEFAN-BOLTZMANN LAW AT LOW TEMPERATURES.

Turn on the thermal radiation cube and allow it to heat up. This takes awhile, so you might want to make your calibration curve while it is heating up. The data are printed on the cube. Once the radiation cube gets to its highest temperature begin to measure the power emitted by a three or four of its surfaces as a function of temperature for the entire temperature range of the cube. You will measure the temperature of the leslie cube by plugging in a multimeter set to measure resistance. Make sure you leave space between the thermopiles and the surfaces you choose to measure so that you can fit in some insulating material- probably at least 10 cm. Try to set each thermopile the same distance from the cube. Make measurements quickly so that the sensor does not heat up when exposed to the source. It is important that the position of the detector does not move throughout the process. Does this data support the Stefan-Boltzmann law? Remember that at low temperatures, energy loss to the surroundings is significant. The net energy transfer goes as  $T^4 - T_0^4$ , where  $T_0$  is room temperature. (You should be able to explain why that is.) Use Kelvin Temperatures in your plots.